



Design Tips

Technical Bulletin #47

Flashing and Weep Holes

Proper flashing and weep holes are essential elements in exterior masonry walls. Together, they provide a means to control moisture in a wall. If not addressed, moisture can have damaging effects on exterior walls. Excessive moisture within masonry can lead to crazing, efflorescence and spalling in some cases. Improper flashing can lead to moisture in the interior of a building. An effective system to deal with exterior moisture penetration is necessary for a properly functioning Cast Stone wall.

A drainage wall, also known as a cavity wall, is the most effective solution for a Cast Stone wall exposed to the elements.

THE DRAINAGE WALL

A drainage wall has five essential elements.

- Exterior wythe of masonry
- A clear cavity, or air space, of at least 1 inch
- An interior wythe of masonry or other backing material
- Flashing at all interruptions in the drainage cavity
- Weep holes at all flashing locations.
Recommended spacing of 24 in. o.c.

The exterior wythe provides first resistance against moisture penetration. Cast Stone should be laid with full joints in mortar meeting the requirements of ASTM C 270, Type N mortar. (See Bulletin #42.) Care should be taken when laying the stone to ensure the cavity behind this wythe stays clear. A tapered bed joint can help minimize mortar droppings and protrusions into the drainage cavity.

A minimum 1 in. cavity or air space is recommended. Cavities of 2 in. or more are easier to keep clear of mortar and debris. Cavities over 4 in. may require special ties and anchors. When insulation is specified, the clear space of the cavity is measured from the outer face of the insulation to the back of the exterior wythe. (See Detail 1.)

Through-wall flashing and weep holes should be used at the base of the drainage wall and at all interruptions in the cavity, such as at window heads and relieving angles. Flashing must be continuous and properly lapped and sealed at the base of the wall and at relieving angles. When flashing is used over openings, such as at windows, end dams are required. (See Detail 2.) Weep holes direct water from the drainage cavity to the outside. Open head joints of at least 1 in. in height are recommended. Open weep hole joints provide the best drainage. They should be spaced no more than 24 in. apart. Rope wicks can also be used, but weep holes should be placed closer together, at 16 in. o.c., since this type does not drain as quickly. Plastic tubes are not recommended because they are easily clogged by mortar or by insects. In stones over 24 in. in length, a 3/8 in. wide by 1 in. high notch through the base of the stone is recommended for drainage. Unnecessarily long lengths of stone are discouraged because adequate drainage between weep holes can be a problem. Moisture retained in the wall can lead to crazing of the Cast Stone.

FLASHING AT BASES

Flashing and weep holes must be used at the base of a cavity (drainage) wall and at all

relieving angles. Flashing should extend from the exterior face of the Cast Stone wythe into the cavity. In the case of a masonry backing wythe, the flashing should be turned up a minimum of 8 in. and extend into the masonry backing. In framed backing walls, the flashing should extend up the cavity at least 8 in. and be attached to the exterior sheathing. Building paper or other water resistant membrane on the interior wythe should overlap the top of the flashing.

Flashing is also recommended below all Cast Stone belt courses and watertables that sit on a relieving angle or occur at a change in material, i.e. stone to brick. In most cases, flashing and weep holes should be placed directly below the Cast Stone course for proper drainage of the cavity. In cases where stone and clay brick are used together in the same wythe, the flashing also serves as a bond break between the Cast Stone and the brick. Because clay brick undergoes irreversible moisture expansion and Cast Stone, like other cementitious products, tends to shrink, flashing between the different courses allows horizontal movement to occur without cracking the mortar joints or units. The Brick Industry Association's Technical Notes 18 Series provides further information on this topic. Stones must be anchored, top and bottom, to the backing material when this detail is used.

FLASHING OVER OPENINGS

Cast Stone window heads and arched openings also require flashing. If the Cast Stone is supported by a relieving angle, flashing and weep holes are located below the stone course, on the relieving angle. When no relieving angle is used, as in the case of structural stone lintels, flashing should be placed directly above the stone course. In either case, proper anchorage of the stone to the backing is imperative.

FLASHING AT COPINGS AND CAPS

Experience has shown that Cast Stone copings perform best when the mortar bond with the masonry wall is maintained. For this reason, flashing should not extend over the full width below the Cast Stone coping. Instead, the flashing should be turned down into the drainage cavity and then out through the exterior supporting wythe below. (See Detail Plate 18) This differs from recommendations found in the Brick Industry Associations Technical Notes.

At chimney caps, step flashing from below the Cast Stone coping down through the first course of supporting masonry below the cap. Weep holes should be located in the head joints of the first course of supporting masonry. (See Detail 3.)

ANCHOR PENETRATIONS THROUGH FLASHING

The anchors for attaching Cast Stone may be required to penetrate flashing and building paper to allow a secure connection to the structure. Where this occurs, proper steps must be taken to ensure a watertight connection at the interface so that the anchor does not compromise the integrity of the flashing. Grommets, thimbles, sleeves, couplings and sealants are available for this purpose, but it is beyond the scope of this Technical Bulletin to provide specific guidance.

FLASHING MATERIALS

Flashing is a key element in a drainage wall. Poor flashing materials can become brittle over time and may allow water to penetrate the building interior. As a result, longevity and life cycle cost should be considered, in addition to first costs, when choosing a flashing material.

Flashing materials used successfully with Cast Stone include stainless steel, copper, copper

laminates, EPDM, and rubberized asphalt. Polyvinyl chloride (PVC) and galvanized steel flashing should be avoided because of their questionable long-term performance. (See the Brick Industry Associations Engineering & Research Digest, "Through-Wall Flashing", for a detailed discussion.) Table 1 lists some advantages and disadvantages of each of the recommended flashing materials that must be considered in making a final selection.

Table 1: RECOMMENDED FLASHING MATERIALS

Material	Minimum Thickness	Advantages	Disadvantages
Stainless Steel	0.01 in. (0.25 mm)	Extremely durable, non-staining	Difficult to solder and form
Cold Rolled Copper	10 ounces/ft ² (3100 g/m ²)	Durable, easily formed, easily joined	Stains adjacent masonry
EPDM	30 mils (0.8 mm)	Felxible, easy to form, easy to join, non-staining	Metal drip edge required, more easily torn
Rubberized Asphalt	30 mils (0.8 mm)	Self-healing, flexible, easy to form, easy to join	Dimensional instability, incompatibility with joint sealant, metal drip edge required
Copper Laminates	5 ounces/ft ² (1500 g/m ²)	Easy to form, easy to join, non-staining	Metal drip edge required, more easily torn

Table printed with permission from the Brick Industry Association Engineering & Research Digest, "Through-Wall Flashing".

This Technical Bulletin is provided by the Cast Stone InstituteSM, and is intended for guidance only. Specific details should be obtained from the manufacturer or supplier of the Cast Stone units.

Copyright © 1986-2002 Cast Stone Institute. All rights reserved.

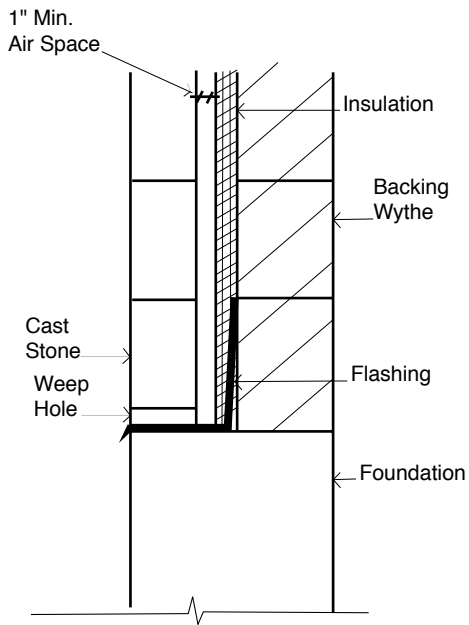

DETAIL 1: Flashing at Base

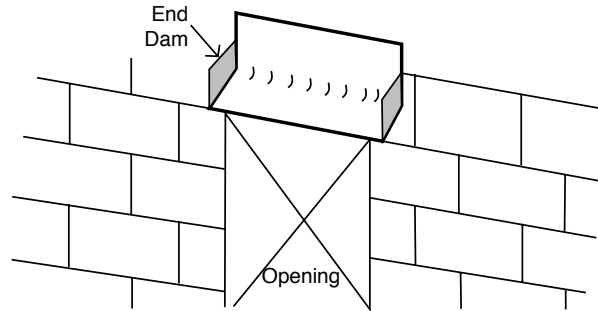

DETAIL 2: Flashing End Dam

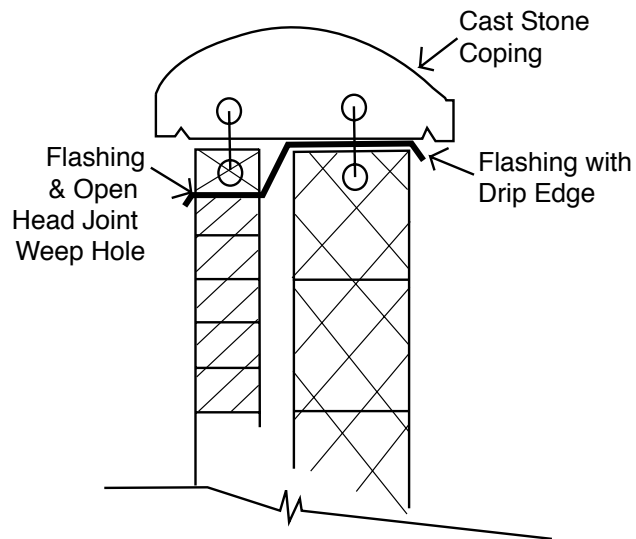

DETAIL 3: Flashing at Copings/Caps

